

Specifications

Model #AN-10S

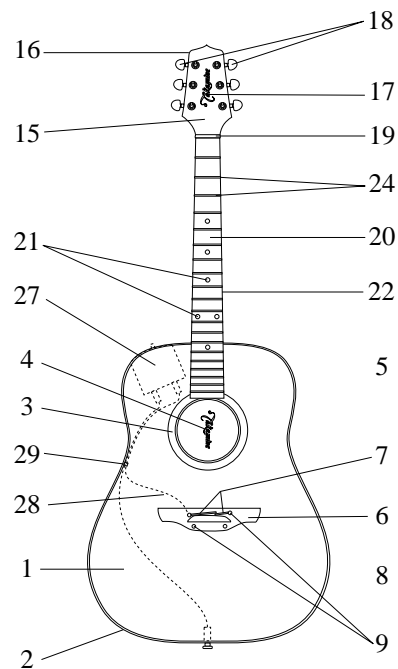

COMPONENT	DESCRIPTION
Body style	Dreadnought
1. Top	Solid Cedar
Top Bracing	D-1
2. Top Binding	Ivory CAB w/ Brown & White wood purfling
3. Rosette	Tinted Wood Rings
4. Soundhole Label/Stamp	Mountain Label
5. Pickguard	N/A
6. Bridge	Rosewood
7. Saddle	Bone - Two Piece Compensated
8. Bridge Pin	N/A
9. Bridge Inlay	White Acrylic/Black Acrylic
Bridge Bolts	Two w/ washers
10. Sides	Solid Mahogany
11. Back	Solid Mahogany
12. Centerline Inlay	Ivory CAB
13. Back Binding	Ivory CAB
14. Strap Pin	End Pin, Ivory w/ Black dot
15. Peghead Face	Rosewood
16. Peghead Binding	N/A
17. Peghead Logo	Gold
18. Machine Heads	Gold w/ Pearloid buttons
19. Nut	Bone
20. Fingerboard	Rosewood
21. Fingerboard Inlay	N/A
22. Fingerboard Binding	N/A
23. Fingerboard Side Markers	White CAB (#3, 5, 7, 9, 12, 15, 17)
24. Frets	Nickel
25. Neck	Mahogany
Truss Rod	Two Way Truss Rod
Neck Joint	14 Fret Dovetail
26. Heel Cap	Ivory CAB
27. Preamp Assembly	N/A
28. Pickup Assembly	N/A
29. Cord Hook	N/A
30. Serial Number	Takamine paper sticker on heel block
Strings	D'Addario EXP light guage
Finish	Satin Polyurethane
DIMENSIONS	(inches rounded off from metric measurements)
A. Scale Length	644 mm 25-3/8" inches
B. Nut Width	42.5 mm 1-11/16"
C. Upper Bout Width	30 cm 11-1/8"
D. Lower Bout Width	40 cm 15-3/4"
E. Total Guitar Length	104 cm 40-15/16"
F. Total Body Length	51 cm 20-1/16"
G. Upper Bout Depth	10 cm 4"
H. Lower Bout Depth	12.5 cm 4-15/16"



BODY

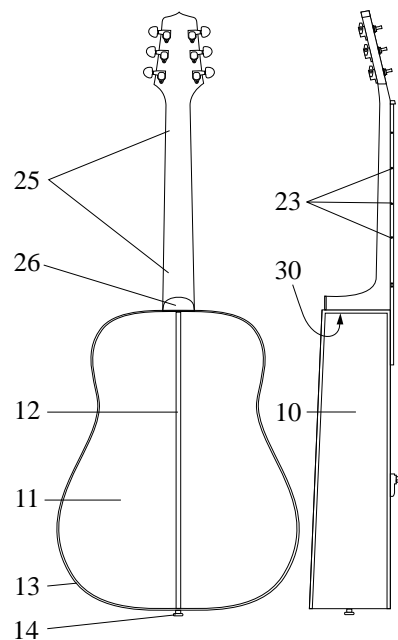

NECK

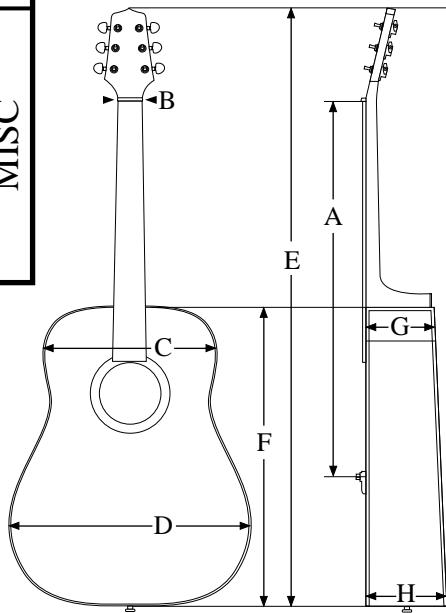

MISC