

# Specifications

## Model #EAC-11C

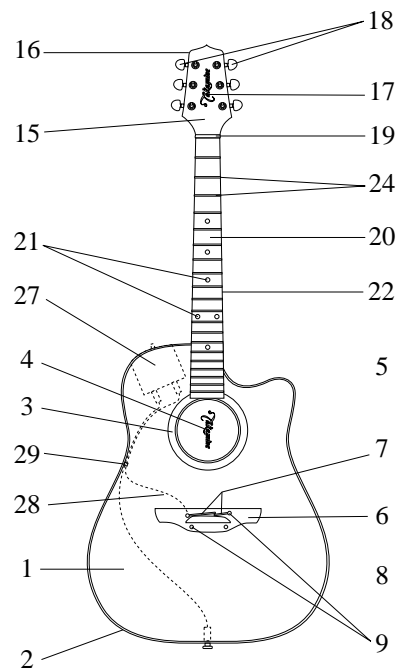

COMPONENT	DESCRIPTION
Body style	Dreadnought Cutaway
1. Top	Solid Spruce
Top Bracing	DC
2. Top Binding	Ivory CAB
3. Rosette	Thunderbird Rosette
4. Soundhole Label/Stamp	Takamine Label
5. Pickguard	N/A
6. Bridge	Indian Rosewood
7. Saddle	Bone - Two Piece Compensated
8. Bridge Pin	N/A
9. Bridge Inlay	White Acrylic / Black Acrylic
Bridge Bolts	Two w/ washers
10. Sides	Mahogany
11. Back	Solid Sapele
12. Centerline Inlay	Ivory CAB
13. Back Binding	Ivory CAB
14. Strap Pin	End Pin Jack, Gold
15. Peghead Face	Rosewood
16. Peghead Binding	N/A
17. Peghead Logo	Gold
18. Machine Heads	Gold w/ Brown Pearloid buttons
19. Nut	Bone
20. Fingerboard	Rosewood
21. Fingerboard Inlay	12th fret Thunderbird inlay
22. Fingerboard Binding	Ivory CAB
23. Fingerboard Side Markers	White Acrylic (#3, 5, 7, 9, 12, 15, 17)
24. Frets	Nickel
25. Neck	Mahogany
Truss Rod	Two Way Truss Rod
Neck Joint	14 Fret Dovetail
26. Heel Cap	Ivory CAB
27. Preamp Assembly	Chromatic Tuner preamp CT-4B
28. Pickup Assembly	Palathetic Pickup
29. Cord Hook	CH1
30. Serial Number	Takamine paper sticker on heel block
Strings	D'Addario EXP light guage
Finish	Gloss Polyurethane
<b>DIMENSIONS</b>	(inches rounded off from metric measurements)
A. Scale Length	644 mm      25-3/8" inches
B. Nut Width	42.5 mm      1-5/8"
C. Upper Bout Width	30 cm      11-1/8"
D. Lower Bout Width	40 cm      15-3/4"
E. Total Guitar Length	104 cm      40-15/16"
F. Total Body Length	51 cm      20-1/16"
G. Upper Bout Depth	10 cm      4"
H. Lower Bout Depth	12.5 cm      4-15/16"



BODY

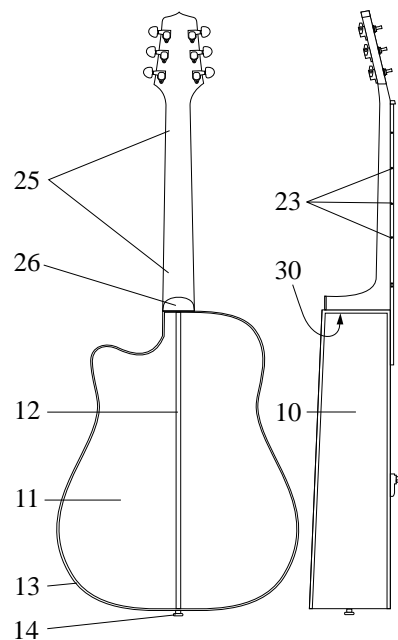

NECK

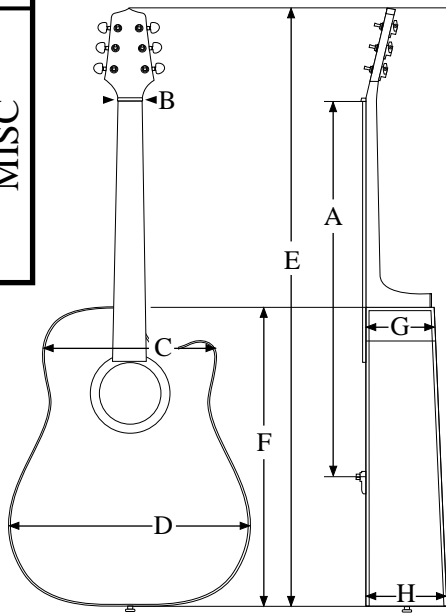

MISC