

Specifications

Model #EAN-60C

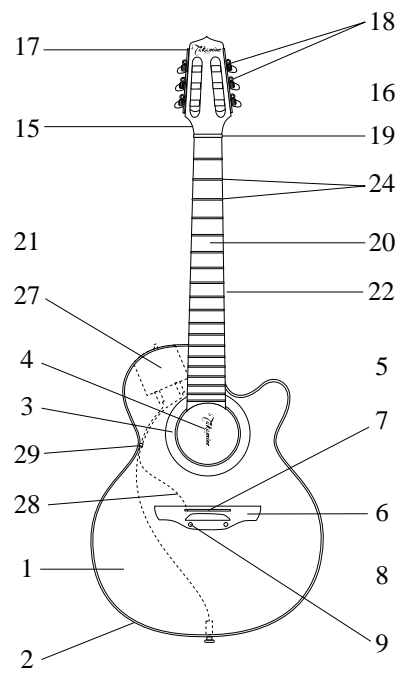

COMPONENT	DESCRIPTION
Body style	FXC (Cutaway)
1. Top	Solid Cedar
Top Bracing	FXC-Nylon
2. Top Binding	Ivory & Brown, CAB
3. Rosette	Tinted Wood Rings
4. Soundhole Label/Stamp	Natural Series Label
5. Pickguard	N/A
6. Bridge	Rosewood
7. Saddle	Bone - Single Piece
8. Bridge Pin	N/A
9. Bridge Inlay	Black Acrylic / White Acrylic
Bridge Bolts	Two w/ washers
10. Sides	Mahogany
11. Back	Solid Mahogany
12. Centerline Inlay	Ivory CAB
13. Back Binding	Ivory CAB
14. Strap Pin	End Pin Jack, Gold
15. Peghead Face	Rosewood
16. Peghead Binding	N/A
17. Peghead Logo	Gold
18. Machine Heads	Gold w/ Pearloid buttons
19. Nut	Bone
20. Fingerboard	Rosewood
21. Fingerboard Inlay	N/A
22. Fingerboard Binding	None
23. Fingerboard Side Markers	White Acrylic (#3, 5, 7, 9, 12, 15, 17)
24. Frets	Nickel
25. Neck	Mahogany
Truss Rod	Soundhole Access
Neck Joint	14 Fret Dovetail
26. Heel Cap	Ivory CAB
27. Preamp Assembly	CT-4B Preamp
28. Pickup Assembly	Palathetic Pickup
29. Cord Hook	CH1
30. Serial Number	Takamine paper sticker on heel block
Strings	Nylon
Finish	Satin Polyurethane
<b>DIMENSIONS</b>	(inches rounded off from metric measurements)
A. Scale Length	650 mm      25-9/16" inches
B. Nut Width	47.5 mm      1-7/8"
C. Upper Bout Width	28 cm      11"
D. Lower Bout Width	37.5 cm      14-3/4"
E. Total Guitar Length	103 cm      40-3/8"
F. Total Body Length	48.5 cm      19-1/8"
G. Upper Bout Depth	9.5 cm      3-3/4"
H. Lower Bout Depth	10 cm      4"



BODY

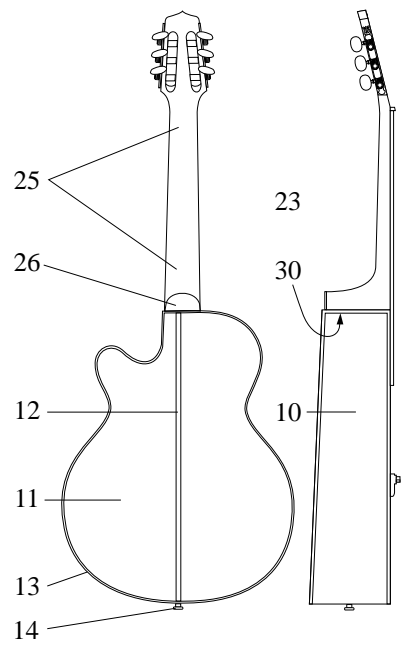

NECK

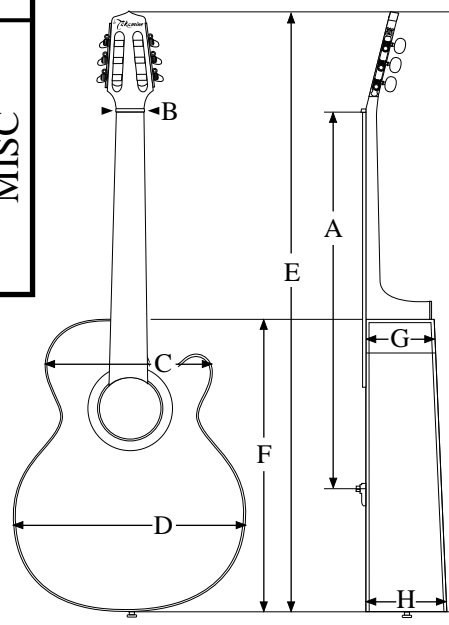

MISC