

# Specifications

## Model #LTD-2000

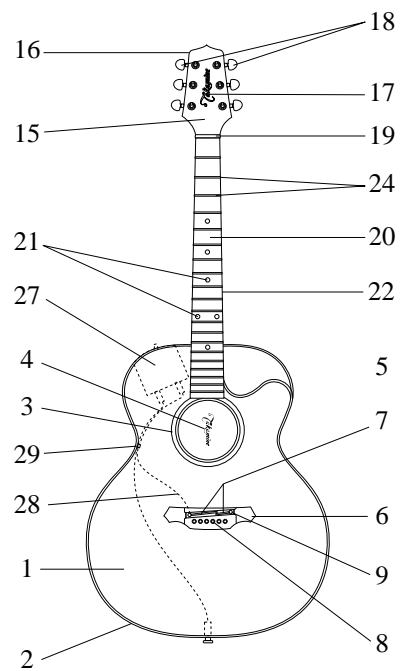

COMPONENT	DESCRIPTION
Body style	NEXC (Cutaway)
1. Top	Solid Spruce
Top Bracing	NC-1
2. Top Binding	Ivory, CAB & Wood
3. Rosette	Constellations/Olive Branches/2000 Ribbon
4. Soundhole Label/Stamp	2000 Label, olive branch/ribbon design
5. Pickguard	N/A
6. Bridge	Rosewood
7. Saddle	Bone - Two Piece Compensated
8. Bridge Pin	White w/ Black Dot
9. Bridge Inlay	White Acrylic
Bridge Bolts	N/A
10. Sides	Rosewood
11. Back	Rosewood
12. Centerline Inlay	Wood Strip, black / wood / black
13. Back Binding	Ivory, CAB & Wood
14. Strap Pin	End Pin Jack, chrome
15. Peghead Face	Rosewood
16. Peghead Binding	N/A
17. Peghead Logo	Gold
18. Machine Heads	Gold w/ Pearloid buttons
19. Nut	Bone
20. Fingerboard	Rosewood
21. Fingerboard Inlay	Orbital Ribbon w/ Stars (includes peghead face)
22. Fingerboard Binding	Rosewood
23. Fingerboard Side Markers	White Acrylic (#3, 5, 7, 9, 12, 15, 17)
24. Frets	Nickel
25. Neck	Mahogany
Truss Rod	Two-Way Truss rod
Neck Joint	14 Fret Dovetail
26. Heel Cap	Ivory, CAB
27. Preamp Assembly	Graph-EX Preamp
28. Pickup Assembly	Palathetic Pickup
29. Cord Hook	CH1
30. Serial Number	Takamine paper sticker on heel block
Strings	Light Gauge
Finish	Gloss Polyurethane
<b>DIMENSIONS</b>	(inches rounded off from metric measurements)
A. Scale Length	644 mm      25-3/8" inches
B. Nut Width	40 mm      1-9/16"
C. Upper Bout Width	28.5 cm      11-1/4"
D. Lower Bout Width	40 cm      15-3/4"
E. Total Guitar Length	105 cm      41-5/16"
F. Total Body Length	51 cm      20-1/16"
G. Upper Bout Depth	9.5 cm      3-3/4"
H. Lower Bout Depth	11 cm      4-5/16"



BODY

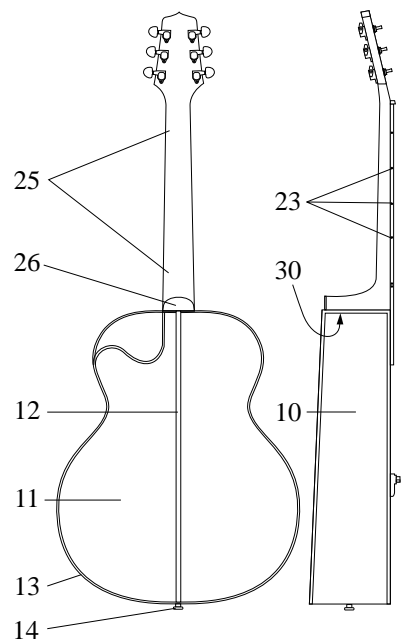

NECK

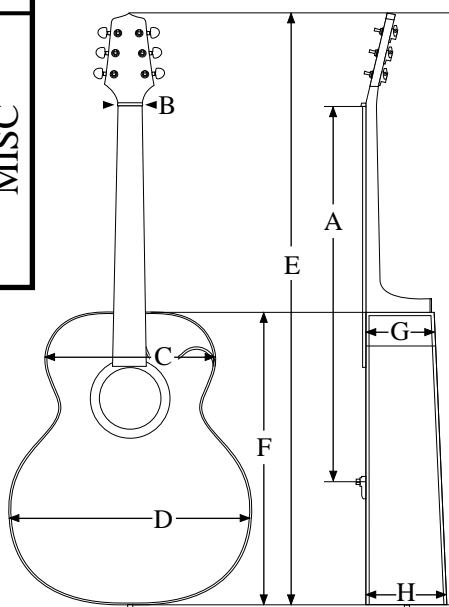

MISC