

Specifications

Model #LTD-2005

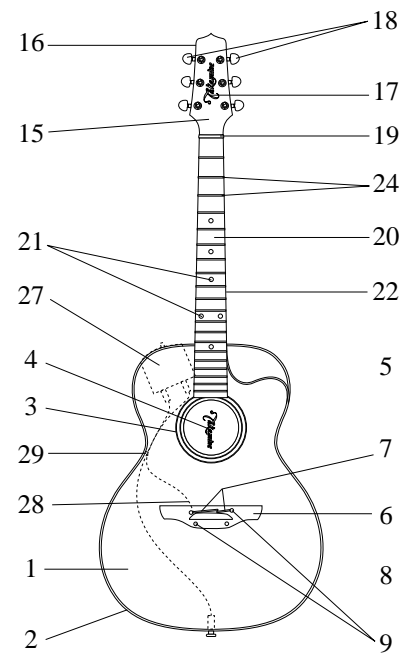

COMPONENT	DESCRIPTION
Body style	Orchestra Model
1. Top	Solid Spruce
Top Bracing	OM-1
2. Top Binding	Ivory, wood, CAB
3. Rosette	'Cattails in the Breeze' extended rosette/top design
4. Soundhole Label/Stamp	Round Cattail Label
5. Pickguard	N/A
6. Bridge	Indian Rosewood
7. Saddle	Bone - Two Piece Compensated
8. Bridge Pin	N/A
9. Bridge Inlay	White Acrylic / Black Acrylic
Bridge Bolts	Two w/ washers
10. Sides	Solid Sepele Mahogany
11. Back	Solid Sepele Mahogany
12. Centerline Inlay	Ivory CAB
13. Back Binding	Ivory CAB
14. Strap Pin	End Pin Jack, chrome
15. Peghead Face	Rosewood
16. Peghead Binding	N/A
17. Peghead Logo	Gold
18. Machine Heads	Gold w/ Amber Pearlloid buttons
19. Nut	Bone
20. Fingerboard	Striped Ebony
21. Fingerboard Inlay	Floating Cattail Seedheads
22. Fingerboard Binding	Ebony
23. Fingerboard Side Markers	White Acrylic (#3, 5, 7, 9, 12, 15, 17)
24. Frets	Nickel
25. Neck	Mahogany
Truss Rod	Two Way Truss Rod
Neck Joint	14 Fret Dovetail
26. Heel Cap	Ivory CAB
27. Preamp Assembly	Chromatic Tuner preamp CT-4B
28. Pickup Assembly	Palathetic Pickup
29. Cord Hook	CH1
30. Serial Number	Takamine paper sticker on heel block
Strings	D'Addario EXP light guage
Finish	Gloss Polyurethane
DIMENSIONS	(inches rounded off from metric measurements)
A. Scale Length	644 mm 25-3/8" inches
B. Nut Width	45 mm 1-3/4"
C. Upper Bout Width	30 cm 11-15/16"
D. Lower Bout Width	39 cm 15-5/16"
E. Total Guitar Length	103 cm 40-9/16"
F. Total Body Length	49 cm 19-7/16"
G. Upper Bout Depth	9.2 cm 3-5/8"
H. Lower Bout Depth	10.8 cm 4-1/4"



BODY

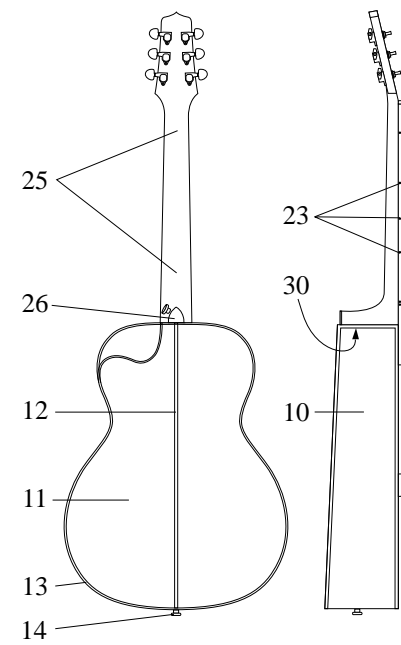

NECK

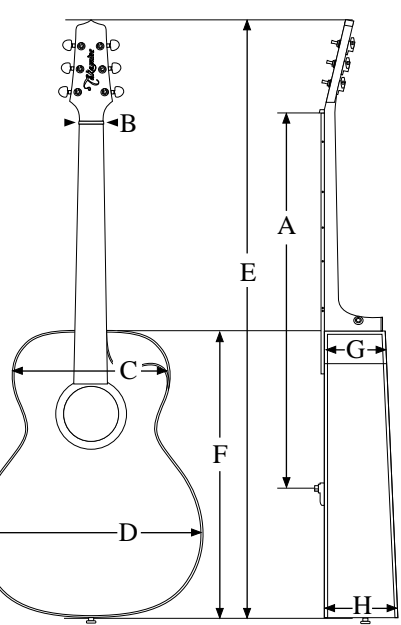

MISC