

Specifications

Model #EAC-38C & #TAC-38C

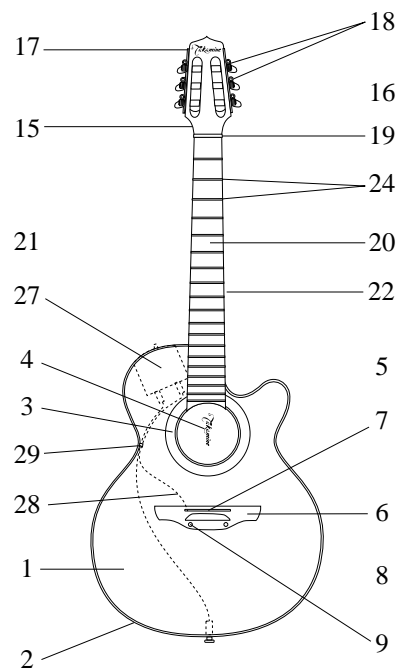

COMPONENT	DESCRIPTION
Body style	FXC (Cutaway)
1. Top	Solid Spruce
Top Bracing	FXC-1
2. Top Binding	Maple binding w/ blue color wood purfling
3. Rosette	Native American design
4. Soundhole Label/Stamp	Natural Series Label
5. Pickguard	N/A
6. Bridge	Rosewood (dyed black)
7. Saddle	Bone - Two Piece Compensated
8. Bridge Pin	N/A
9. Bridge Inlay	Black Acrylic / White Acrylic
Bridge Bolts	Two w/ washers
10. Sides	Rosewood
11. Back	Solid Rosewood
12. Centerline Inlay	Maple & blue color wood
13. Back Binding	Maple binding w/ blue color wood purfling
14. Strap Pin	End Pin Jack, Gold
15. Peghead Face	Rosewood
16. Peghead Binding	N/A
17. Peghead Logo	Abalone
18. Machine Heads	Gold w/ Pearloid buttons
19. Nut	Bone
20. Fingerboard	Ebony
21. Fingerboard Inlay	Native American design
22. Fingerboard Binding	Ebony
23. Fingerboard Side Markers	White Acrylic (#3, 5, 7, 9, 12, 15, 17)
24. Frets	Nickel
25. Neck	Mahogany
Truss Rod	Soundhole Access
Neck Joint	14 Fret Dovetail
26. Heel Cap	Maple
27. Preamp Assembly	CT4B (EAC-38C), CTP-1 Preamp (TAC-38C)
28. Pickup Assembly	Palathetic Pickup
29. Cord Hook	CH1
30. Serial Number	Takamine paper sticker on heel block
Strings	D'Addario EXP light guage
Finish	Satin Polyurethane
DIMENSIONS	(inches rounded off from metric measurements)
A. Scale Length	650 mm 25-9/16" inches
B. Nut Width	47.5 mm 1-7/8"
C. Upper Bout Width	28 cm 11"
D. Lower Bout Width	37.5 cm 14-3/4"
E. Total Guitar Length	103 cm 40-3/8"
F. Total Body Length	48.5 cm 19-1/8"
G. Upper Bout Depth	9.5 cm 3-3/4"
H. Lower Bout Depth	10 cm 4"



BODY

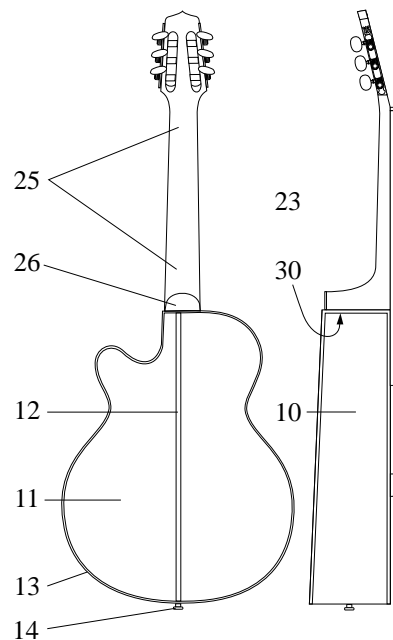

NECK

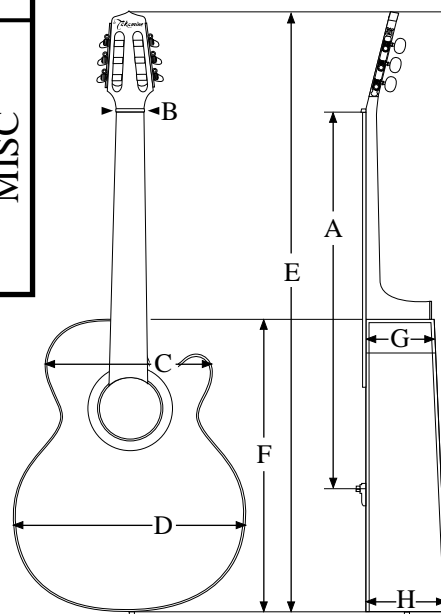

MISC