

Specifications

Model #EAC-48C & TAC-48C

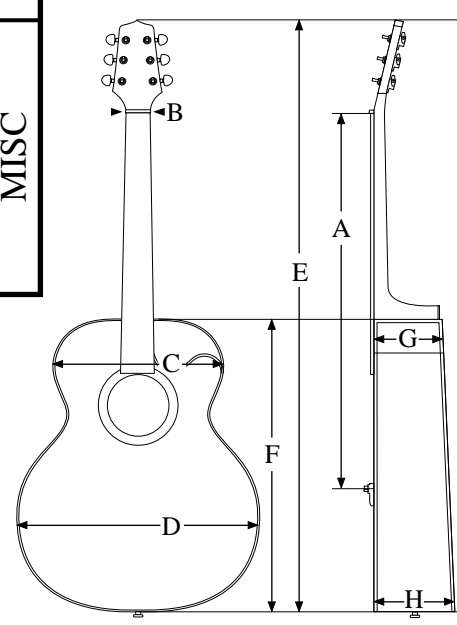

COMPONENT	DESCRIPTION
Body style	NEXC (Cutaway)
1. Top	Solid Spruce
Top Bracing	NC-1
2. Top Binding	Maple binding w/ blue color wood purfling
3. Rosette	Native American design
4. Soundhole Label/Stamp	Santa Fe Label
5. Pickguard	N/A
6. Bridge	Rosewood (dyed black)
7. Saddle	Bone - Two Piece Compensated
8. Bridge Pin	N/A
9. Bridge Inlay	White Acrylic / Black Acrylic
Bridge Bolts	Two w/ washers
10. Sides	Rosewood
11. Back	Solid Rosewood
12. Centerline Inlay	Maple & Blue color wood
13. Back Binding	Maple binding w/ blue color wood purfling
14. Strap Pin	End Pin Jack, Chrome
15. Peghead Face	Rosewood
16. Peghead Binding	N/A
17. Peghead Logo	Abalone
18. Machine Heads	Chrome
19. Nut	Bone
20. Fingerboard	Ebony
21. Fingerboard Inlay	Native American design
22. Fingerboard Binding	Ebony
23. Fingerboard Side Markers	White Acrylic (#3, 5, 7, 9, 12, 15, 17)
24. Frets	Nickel
25. Neck	Mahogany
Truss Rod	Soundhole Access
Neck Joint	14 Fret Dovetail
26. Heel Cap	Maple
27. Preamp Assembly	CT4B (EAC-48C), CTP-1 Preamp (TAC-48C)
28. Pickup Assembly	Palathetic Pickup
29. Cord Hook	CH1
30. Serial Number	Takamine paper sticker on heel block
Strings	D'Addario EXP light guage
Finish	Gloss Polyurethane
DIMENSIONS	(inches rounded off from metric measurements)
A. Scale Length	644 mm 25-3/8" inches
B. Nut Width	42.5 mm 1-5/8"
C. Upper Bout Width	28.5 cm 11-1/4"
D. Lower Bout Width	40 cm 15-3/4"
E. Total Guitar Length	105 cm 41-5/16"
F. Total Body Length	51 cm 20-1/16"
G. Upper Bout Depth	9.5 cm 3-3/4"
H. Lower Bout Depth	11 cm 4-5/16"

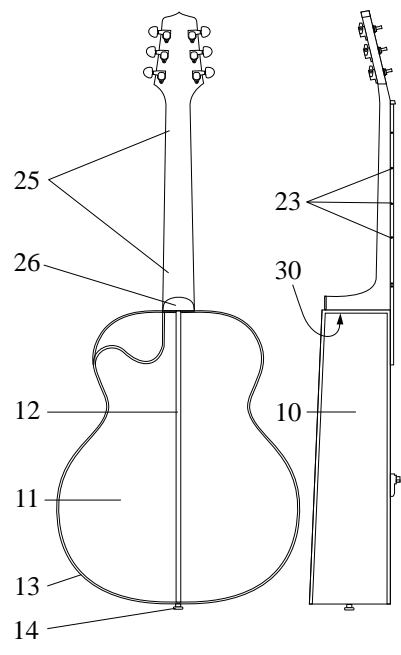
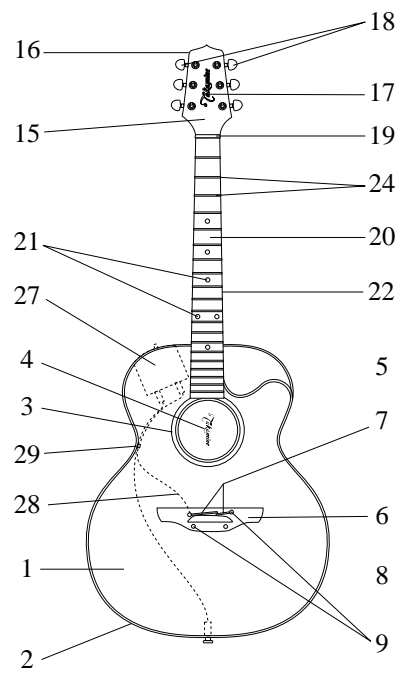

BODY

NECK

MISC