

Specifications

Model #TAN-76C

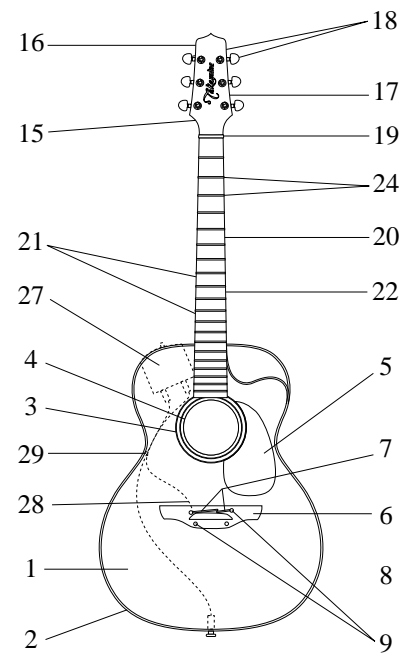

COMPONENT	DESCRIPTION
Body style	Orchestra Model Cutaway
1. Top	Solid Spruce
Top Bracing	OMC-1
2. Top Binding	Ivory CAB w/ Abalone
3. Rosette	Abalone
4. Soundhole Label/Stamp	Mountain Label
5. Pickguard	Tortoise Shell
6. Bridge	Rosewood
7. Saddle	Bone - Two Piece Compensated
8. Bridge Pin	N/A
9. Bridge Inlay	White Acrylic
Bridge Bolts	Two w/ washers
10. Sides	Rosewood
11. Back	Solid Rosewood
12. Centerline Inlay	Wood
13. Back Binding	Ivory CAB w/ Brown & White wood purfling
14. Strap Pin	End Pin Jack, Gold
15. Peghead Face	Rosewood
16. Peghead Binding	N/A
17. Peghead Logo	Gold
18. Machine Heads	Gold w/ Pearloid buttons
19. Nut	Bone
20. Fingerboard	Rosewood
21. Fingerboard Inlay	N/A
22. Fingerboard Binding	N/A
23. Fingerboard Side Markers	White CAB (#3, 5, 7, 9, 12, 15, 17)
24. Frets	Nickel
25. Neck	Mahogany, Wide
Truss Rod	Two-Way Truss rod
Neck Joint	14 Fret Dovetail
26. Heel Cap	Ivory, CAB
27. Preamp Assembly	Cool Tube Preamp (CTP-1)
28. Pickup Assembly	Palathetic Pickup
29. Cord Hook	CH1
30. Serial Number	Takamine paper sticker on heel block
Strings	D'Addario EXP Light Gauge
Finish	Gloss Polyurethane
DIMENSIONS	(inches rounded off from metric measurements)
A. Scale Length	644 mm 25-3/8" inches
B. Nut Width	45 mm 1-3/4"
C. Upper Bout Width	28.5 cm 11-1/4"
D. Lower Bout Width	40 cm 15-3/4"
E. Total Guitar Length	105 cm 41-5/16"
F. Total Body Length	51 cm 20-1/16"
G. Upper Bout Depth	9.5 cm 3-3/4"
H. Lower Bout Depth	11 cm 4-5/16"



BODY

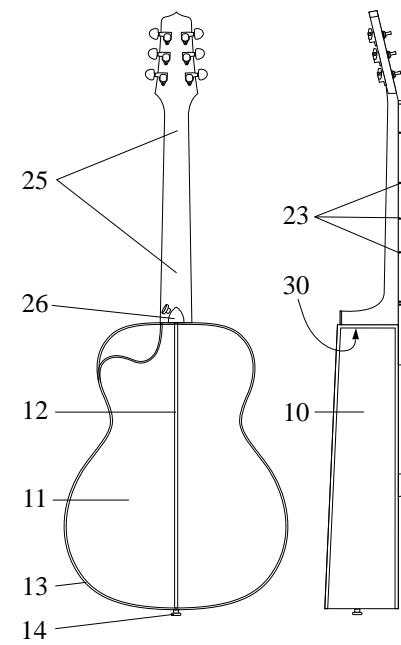

NECK

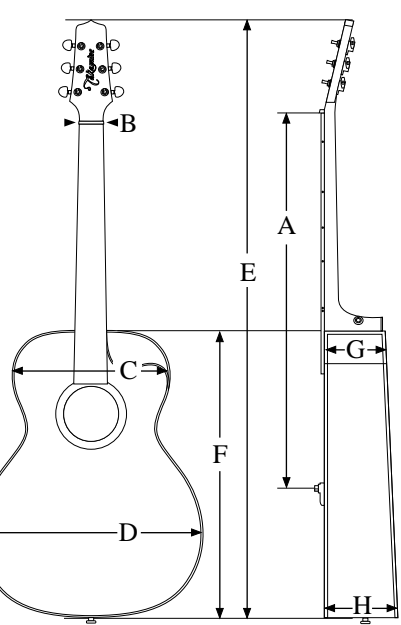

MISC