

# Specifications

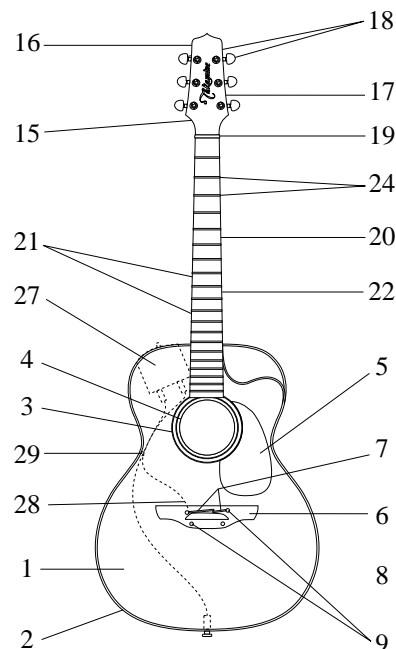

## Model #EAN-77 & TAN-77

COMPONENT	DESCRIPTION
Body style	Orchestra Model
1. Top	Solid Cedar
Top Bracing	OM-1
2. Top Binding	Ivory CAB w/ Brown & White wood purfling
3. Rosette	Abalone
4. Soundhole Label/Stamp	Mountain Label
5. Pickguard	Tortoise Shell
6. Bridge	Rosewood
7. Saddle	Bone - Two Piece Compensated
8. Bridge Pin	N/A
9. Bridge Inlay	White Acrylic
Bridge Bolts	Two w/ washers
10. Sides	Solid Koa
11. Back	Solid Koa
12. Centerline Inlay	Brown & White wood purfling
13. Back Binding	Ivory CAB w/ Brown & White wood purfling
14. Strap Pin	End Pin Jack, Gold
15. Peghead Face	Rosewood
16. Peghead Binding	N/A
17. Peghead Logo	Gold
18. Machine Heads	Gold w/ Gold buttons
19. Nut	Bone
20. Fingerboard	Rosewood
21. Fingerboard Inlay	N/A
22. Fingerboard Binding	N/A
23. Fingerboard Side Markers	White CAB (#3, 5, 7, 9, 12, 15, 17)
24. Frets	Nickel
25. Neck	Mahogany, Wide
Truss Rod	Two-Way Truss rod
Neck Joint	14 Fret Dovetail
26. Heel Cap	Ivory, CAB
27. Preamp Assembly	CT4B Preamp (EAN-77) • CTP-1 (TAN-77)
28. Pickup Assembly	Palathetic Pickup
29. Cord Hook	CH1
30. Serial Number	Takamine paper sticker on heel block
Strings	D'Addario EXP Light Gauge
Finish	Gloss Polyurethane
<b>DIMENSIONS</b>	(inches rounded off from metric measurements)
A. Scale Length	644 mm      25-3/8" inches
B. Nut Width	45 mm      1-3/4"
C. Upper Bout Width	28.5 cm      11-1/4"
D. Lower Bout Width	40 cm      15-3/4"
E. Total Guitar Length	105 cm      41-5/16"
F. Total Body Length	51 cm      20-1/16"
G. Upper Bout Depth	9.5 cm      3-3/4"
H. Lower Bout Depth	11 cm      4-5/16"



BODY

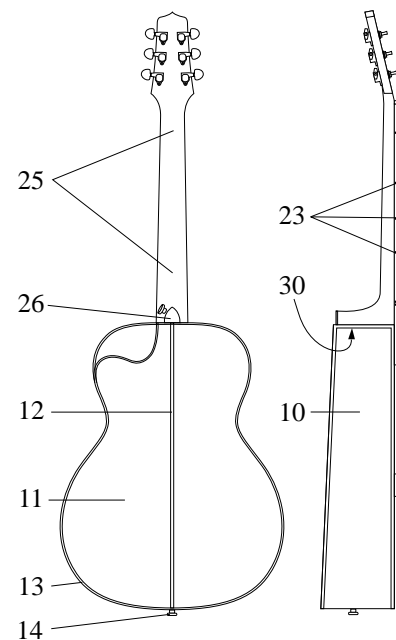

NECK

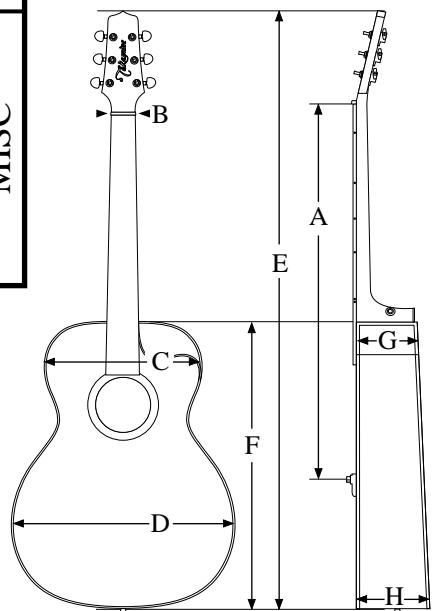

MISC